

Ethernet Photovoltaic Data logger

TK-E20-XX series

1. General

Taoke Ethernet data logger for Photovoltaic plants collects the operation data, including inverter, weather station, meter data, etc by RS485/422, and sends these data to website via Ethernet .

User can check the plants status by logging on to the Platform Website. (www.smart-pv.net)



2. Parts List

- 1.TK-G01 Data logger Series
- 2.Power Adapter(100-220VAC input, 12VDC/1A output)
- 3.Manual

3.Parameter

Power supply	100~240V(AC) / 12V 1A(DC)
Static power consumption	< 2W
Active power consumption	< 5W
Indication for status	4 front + 1 back
Internet connection	Ethernet
Ethernet connection	10BASE-T/100BASE-TX
Ethernet interface	RJ45-CAT5
Device connection	RS485/422
RS485/422 baudrate	1200~38.4K bps
RS485/422 cable length	≤1000m
RS485/422 interface	RJ45
Data collection interval	5~30min
Operation Temp.	-10~55°C(14~131°F)
Protection type	IP21(Indoor)
Installation	Wall or flat
LXWXH	135 × 85 × 25mm

4. .Naming Method

TK-E20-x x

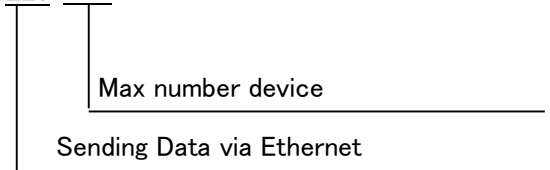

5. I/O illustration



RESET: Key for reset to “IP address allocated via DHCP automatically”

GSM: GSM indicator

LAN: Ethernet socket

485/422: RS485/422 socket

--G+ : DC power socket

6. Monitoring layout

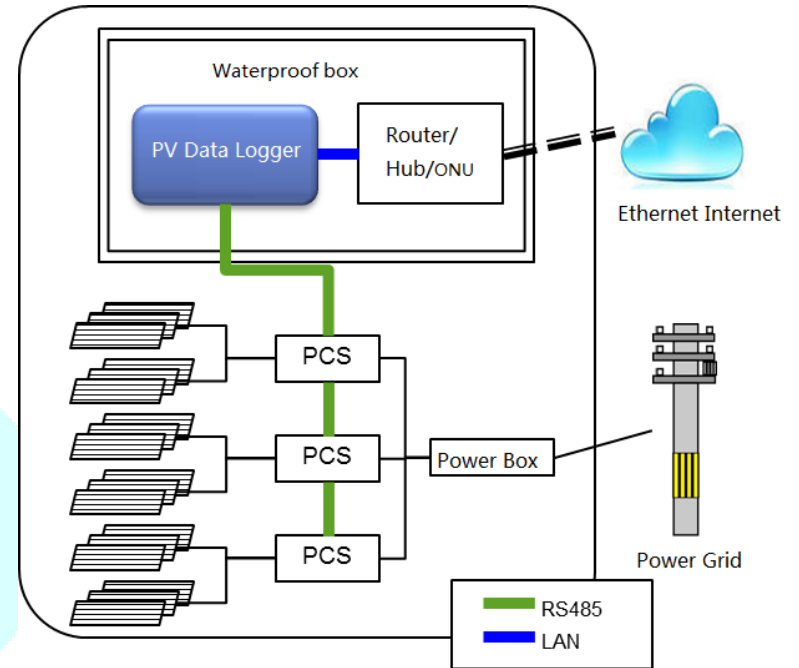

Collect the photovoltaic plants data and alarm by RS485/422 line connecting to plants devices. The data is sent to platform Database by GPRS mobile network.

7. Installation procedure

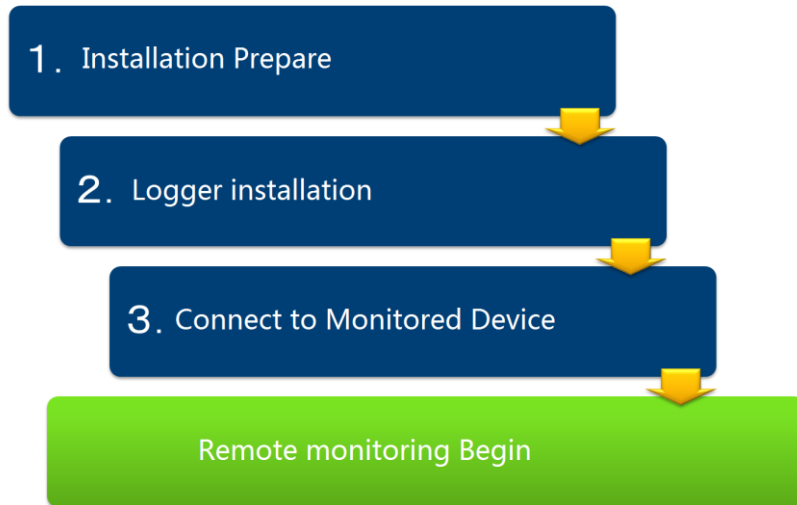

7-1.Preparation

1. Monitored device confirm
Please confirm the monitored devices and loggers work ok before monitoring system do the connecting.
2. Internet confirm
Please confirm that there are internet resource in device area to make the GPRS logger send the data to platform Database.(GPRS signal should be confirmed.)
3. Power support confirm
Please confirm there are enough power support in installation zone for logger or modern(when Ethernet logger need be connected to modern or router).
4. Material and Tools
Please prepare these material and tools before installation.

Material

1	RJ45 terminal	Basing on the quantity of the loggers
2	RS485 lines Shielded twisted pair (STP), or lines attached in devices, or RS485 dedicated.	
3	Standard Ethernet lines	
4	Lines, breaker, socket	
5	Waterproof box(IP65 for the special situation)	
6	ONU/modem/Router/hub (Different Special situations)	

Tools

1	Cable Strippers
2	Diagonal pliers
3	Various sizes of screwdrivers (Plus / minus)
4	Resistance Components (120Ω と 150Ω)
5	Tester (Multimeter、Insulation pen)

7-2. Logger installation

1. Installation

Logger should be set in dried and ventilation situation. It can be set on the wall or put level place. If it is set on the wall, there will be 2 installing holes which can be used to fix.

2. Power protection

Please set the socket and breaker basing on the local rules.

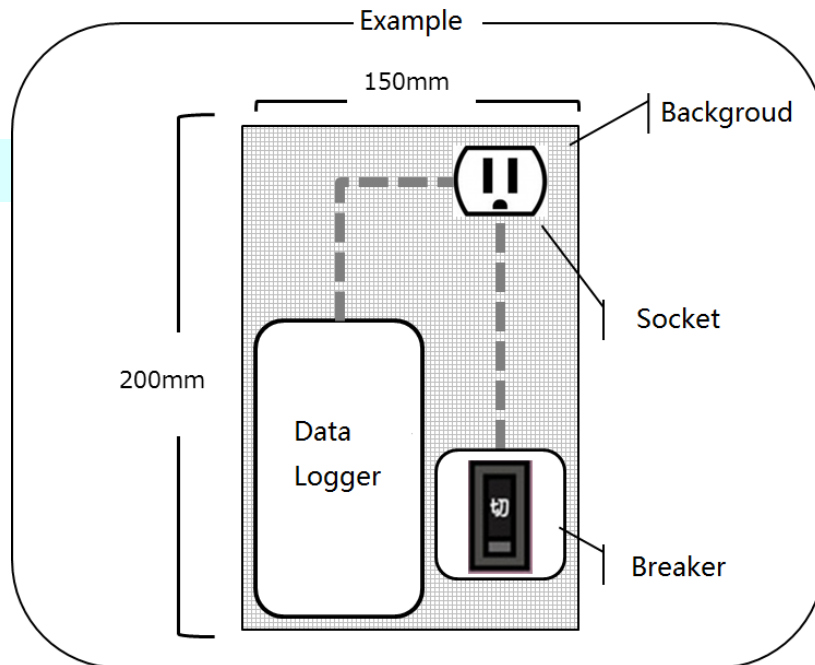

7-3. Connect to monitored devices

1. RS485 line make method

Please make the RS 485 +(A) and 485 -(B) and GND connect to RJ45 Line 4 and Line 5 and Line 8 point. This 485 line length will be longer than the distance between logger and devices.

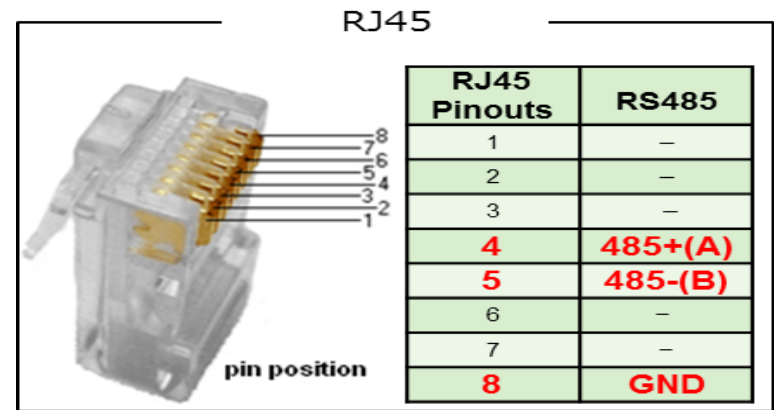

2. Connect the RS485 port to monitored devices with RS485 line .About line and port, please consult the installation manual.

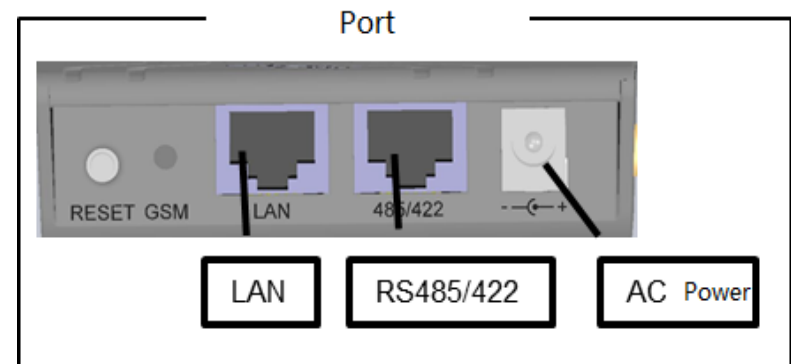

8. LED instructions

3. Logger start up

Connect the logger power to socket. Switch the power. Please confirm the Logger LED light and finish the installation.

- POWER : On
- 485/422 :Blink in few minutes
- GSM :On-Blink

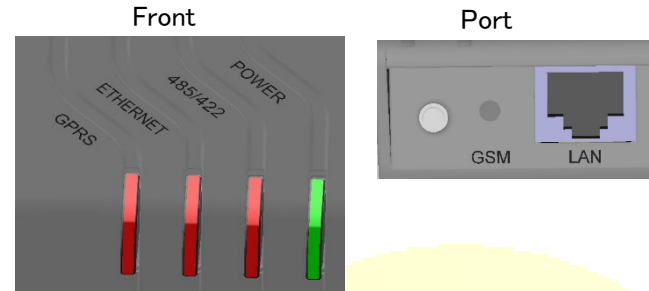
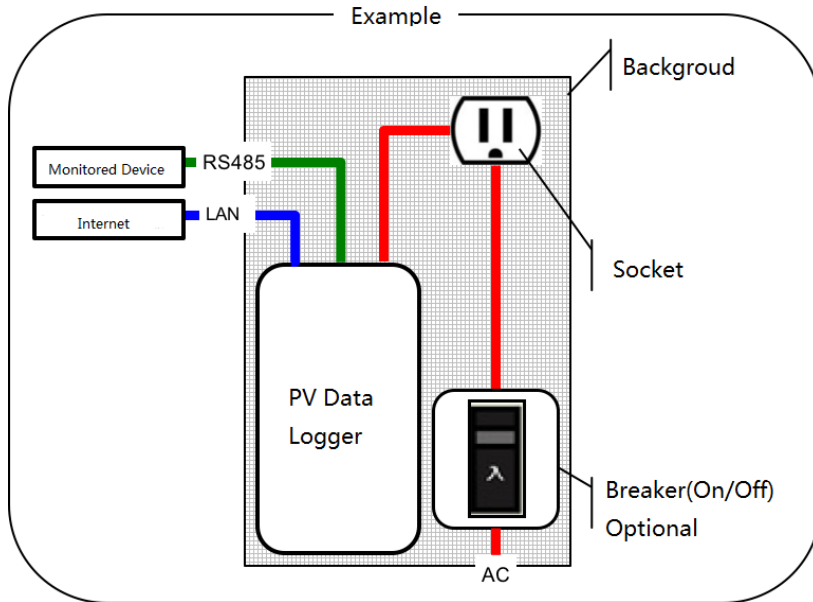

POWER	Always	: On
485/422	Off	: No devices on line
	Fast blink	: Now collecting
	Always	: All is ok
	Slow blink	: few device can't be connected
ETHERNET	Off	: No internet
	Always	: internet is ok
	Fast blink	: seek the IP address
	Slow blink	: Abnormal for seeking
GPRS	Off	: No GPRS net
	Always	: GPRS is ok
	Fast blink	: seek the GPRS net
	3 Fast blink	: SIM is not ready
GSM	Off	: No GPRS net
	Always	: Seek the GPRS signal
	Slow blink	: GPRS is ok
	Fast blink	: Exchange
LAN	Off	: No Ethernet
	Blink	: Ethernet is ok

Data Logger Troubelshooting

LED	Reason	Troubleshooting
Power Off	DC power don't connect or get loose	Check the line and reconnect.
	Adaptor bad	Change the power adaptor.
RS485/422 Off /Blink	It's not connected or get loose	Check the cable among the logger and PV device.
	Device fault	Confirm which one is bad ,logger or monitored device
	Set error	Check the logger setting and confirm if the information is right.
ETHERNET Off	It's not connected or get loose	Reconnect the cable. Check the LED light on Logger and router to confirm if 2 lights are on.
ETHERNET Blink	IP address error	If the light is keeping blinking, It mean that Automatically obtaining IP address failed. Please try to reset the logger. Other way , you can modify the IP address set

		to over-screw.
No signal		You can test the signal by your mobile and move the logger to the good place.
communication module bad		Disconnect logger and power adapter for 15 minutes, then turn on logger, make sure the GSM light from the flash lit to state.
SIM card bad		Pick out the sim card and insert it again. Or change a new one.
Other		Change the logger

LED	Reason	Troubleshooting
GPRS Off/Blink	Antenna is bad	Please screw the antenna when it's get loose. When you do the action, please be careful not